

Receiver

SM0615R100P-A



DIMENSIONS

UNIT: mm

Tolerance: ± 0.5 mm

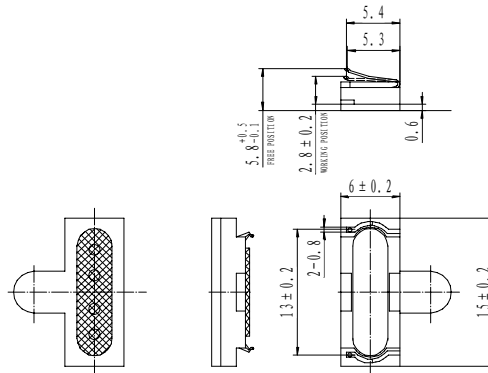

FREQUENCY RESPONSE



SPECIFICATIONS:

Dimension(mm)	6*12*H2.6
Input Power(mW)	10
Max. Input Power(W)	20
Impedance(Ω)	32 \pm 15%@1kHz
S.P.L. (dB)	113 \pm 3dB(1kHz/179mV)
Frequency Rang (Hz)	300-3400
Operating temp. ($^{\circ}$ C)	-20~+60
Weight (g)	1.0
Material	SPCC